



## 2.6. Zeiss GT2 1.67

### Product Specifications

#### Material Data

- MR7 High-index
- Index 1.659  $n_d$
- Abbe 32
- Specific Gravity 1.35
- 100% UVA and 100% UVB Protection

#### Lens Processing

- Zeiss GT2 1.67 lenses can be processed like any other quality 1.67 high-index progressive lens.
- After blocking, wait 30 minutes before generating to allow the blocked lenses to cool.
- Zeiss recommends de-blocking by cold knock-off or block ejector, but not by hot water.
- In order to achieve sunlens density with GT2 1.67 lenses, a tintable back-side coating must be applied.
- All 1.67 lenses emit a characteristic odor while being processed; this odor is proven to be non-toxic.

#### Thickness Guidelines

Progressive lenses of this type that satisfy the thickness guidelines provided below have demonstrated the minimum level of impact resistance during performance testing. However, the ultimate impact strength of a lens depends upon several factors, including the particular combination of coatings and treatments applied to it, and conformance to the FDA regulation is the responsibility of subsequent processors.

Power Range	Minimum Recommended Thickness
-16.00 D to -2.00 D	1.5 mm Center
-1.75 D to +1.25 D	2.0 mm Center and 1.0 mm Edge*
+1.50 D to +4.00 D	1.0 mm Edge
+4.25 D to +6.00 D	0.5 mm Edge

\* Whichever is the limiting factor

#### Delivery Range

- Spheres -16.00 D to +6.00 D (cut-out may be limited in high minus powers)
- Cylinders out to -4.00 D (total power not to exceed -16.00 D)
- Additions +1.00 D to +3.00 D
- Prism up to 3.00  $\Delta$  in addition to prism-thinning



## Hard Coating

Zeiss GT2 1.67 semi-finished lens blanks feature a factory-applied, semi-tintable scratch resistant coating.

## Lens Specification Data

The following table provides the average blank geometry of Zeiss GT2 1.67 lenses. Note that, since the GT2 lens blank is decentered, the effective diameter for cut-out is larger than the actual diameter.

Nominal Base Curve	Act/Effec Diameter [mm]	Blank Decent. [mm]	True Curve [1.53 D]	Front Radius [mm]	Back Curve [1.53 D]	Center Thickness [mm]	Edge Thickness [mm]
0.70	71/76	2.5	0.69	768.1	-6.00	11.5	17.2
1.40	76/81	2.5	1.34	395.5	-6.00	11.8	17.2
2.10	76/81	2.5	2.13	248.8	-6.00	8.1	13.2
3.10	76/81	2.5	3.08	172.1	-6.00	7.8	11.2
4.00	76/81	2.5	3.96	133.8	-6.00	9.0	11.2
4.90	76/81	2.5	4.84	109.5	-6.00	8.2	9.2
6.00	76/81	2.5	6.06	87.5	-6.00	9.5	9.2



## Prism-Thinning

Zeiss progressive lenses are designed to work perfectly with thickness reducing prism (i.e., *prism-thinning*). This will ensure the thinnest and lightest lenses possible. If surfacing software that calculates prism-thinning automatically is not available, Zeiss recommends the use of the following base down (270°) prism:

Addition [D]	1.00	1.25	1.50	1.75	2.00	2.25	2.50	2.75	3.00
Prism [Δ]	0.50	1.75	1.75	1.00	1.25	1.50	1.50	1.75	2.00

## Permanent Engravings

Zeiss GT2 1.67 lenses are marked with the following permanent, semi-visible engravings that indicate the lens design type (Zeiss GT2 = A), lens material type ( $n = 1.67$ ), and addition power (+1.00 to +3.00):

Nasal Engraving	Temporal Engraving
 A67	 10-30

### Semi-Finished Ink Markings

For processing purposes, the blank is marked with a small cross at the geometric center. Since the Zeiss GT2 lens blank is decentered, Zeiss recommends blocking the lens at the geometric center in order to avoid unwanted prism during the fining operation, unless the blank is first cribbed at the generator.

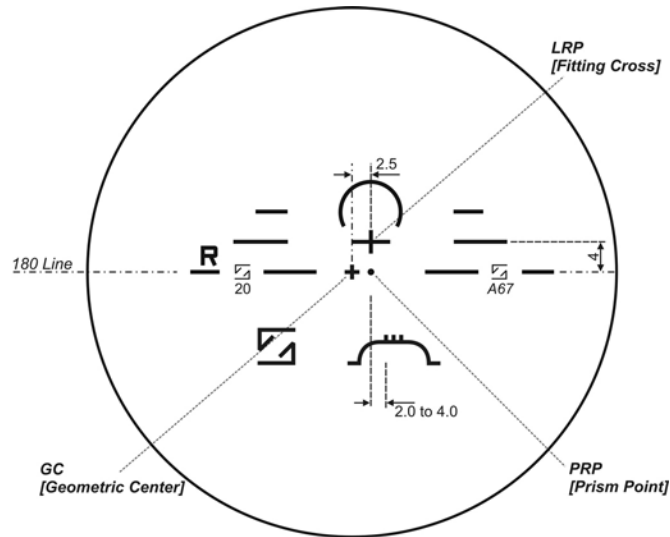

### Finished Verification Markings

Please note that the verification markings of finished Zeiss GT2 lenses differ slightly from the semi-finished ink markings in that the finished lenses are delivered to the eyecare professional without the geometric center cross. Static-type verification masks are available from Carl Zeiss Vision (Item #0080138.00110).

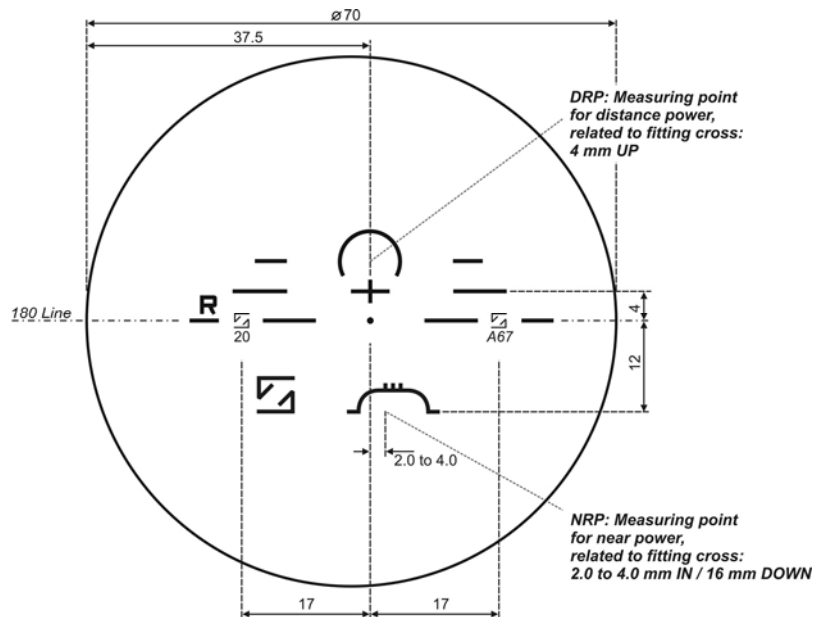



### Base Curve Selection

Always use the recommended base curve; failure to do so may compromise optical performance:

